

TORS

Torsional Orthopaedic Revision System

User Manual - USA

ARCHIVED COPY:

DO NOT USE



CONTENTS

ARCHIVED COPY: 4

DO NOT USE 5

CLINICAL BENEFIT 5

PLEASE NOTE: 5

INDICATIONS 5

CONTRAINDICATIONS 5

CYBERSECURITY 5

THE TORS SYSTEM 6

OVERVIEW 6

GENERATOR 6

Front Panel 6

Rear Panel 6

TORS Transducers & Cables 7

SEE APPENDIX 1 FOR THE SINGLE USE PROBE TYPES AND PART NUMBERS. 8

SAFETY  8

WARNINGS 8

CAUTIONS 10

ELECTROMAGNETIC INTERFERENCE 11

COMPLICATIONS AND POTENTIAL SIDE-EFFECTS 12

MDR REPORTABLE EVENT (OR REPORTABLE EVENT) 13

INSTRUCTIONS FOR USE 14

SETTING UP THE TORS SYSTEM 14

Power up the Generator 14

Optional - Attach the "Cement" footswitch to the Rear Panel 14

Cement Transducer - Connect 15

Cement Transducer - Initialise 16

Cement Transducer - Activate 16

<i>Cement Removal – Irrigation</i>	17
<i>Fume Extraction</i>	17
<i>Performance Characteristics</i>	17
<i>Turn Off TORS</i>	18
FAULT / WARNING INDICATORS: (SEE ALSO APPENDIX 4: TONES AND BEEPS)	18
DECONTAMINATION	20
• <i>After Use Re-Processing</i>	21
• <i>Single Use Items</i>	22
• <i>Reusable Items</i>	22
○ MANUAL CLEANING	22
○ AUTOMATED CLEANING	22
• CLEANING INSPECTION	23
• WRAPPING	23
• STERILIZATION	23
• DRYING TIME	23
• <i>End of Life Management</i>	23
• <i>Opened in Error</i>	23
• <i>Cleaning the Generator</i>	24
• <i>Cleaning the Footswitch</i>	24
EQUIPMENT CARE	24
<i>Transducer / Probe Usage</i>	24
<i>Storage of Equipment between Cases</i>	25
<i>Maintenance</i>	25
<i>Technical Support</i>	25
APPENDICES	26
APPENDIX 1:	26
A. TORS NON-STERILE SYSTEM AND ACCESSORY PART NUMBERS	26
B. TORS STERILE CONSUMABLE PART NUMBERS	26
APPENDIX 2: MARKINGS ON THE TORS FRONT AND BACK PANELS	30
APPENDIX 3: ELECTROMAGNETIC INTERFERENCE	32
APPENDIX 4: TONES AND BEEPS	34
APPENDIX 5: REAR PANEL MESSAGES	35

Conventions used in this document

Warning:



A statement that if not strictly followed could result in injury or loss of life, or a statement that is otherwise required to be a warning.

Caution:

A statement that if not strictly followed could result in damage to the equipment

Contact Information

If the unit requires repair, please contact us through our US agent or directly:

Manufacturer:

Radley Scientific Ltd.
Bremridge House
Bremridge
Ashburton
Devon
TQ13 7JX
UK

Email: enquiries@tors.co.uk

Phone: +44 (0)1364 653899

Website: www.tors.co.uk

US Agent and Importer:

DAWA MEDICAL LLC
7320 NW 12th Street,
Suite 103,
Miami,
Florida,
33126 USA

Email : customerservices@dawamedical.com

Phone: (305) 599-9373

Website: dawamedical.com/

Intended Purpose

TORS is an ultrasonic surgical device intended to be used for removal of polymethylmethacrylate (PMMA) bone cement in orthopaedic applications.

Intended user

TORS is intended to be used by surgical staff experienced with the operation of ultrasonic devices for cement removal, in a professional clinical setting. See relevant Warnings.

Target Population

There are no specific restrictions based on age, weight, health status or ethnicity. No specific patient populations have been defined but patients with contraindication are to be excluded, see Contraindications.

Clinical Benefit

- During treatment with TORS, the patient benefits from ultrasound bone cement removal.
- **TORS is a state-of-the-art device for efficient cement removal in orthopaedic revision surgeries.** It provides clinical benefit over mechanical cement removal methodologies through reduced risk of perforation compared to conventional **mechanical** methods.

Please note:

- This document does not reference surgical techniques.
- The safety & effectiveness of any ultrasonic surgical equipment is mostly dependent upon the surgeon and nursing staff.

Indications

TORS is indicated for use in the removal of polymethylmethacrylate (PMMA) bone cement in orthopaedic applications.

Contraindications

- Do not use, if in the judgment of the surgeon, the use of ultrasonic surgical techniques is not in the best interest of the patient.
- Do not use for incising bone.

Cybersecurity

Neither the generator nor any other component accessory of this device can be connected to an external network of any kind; no external connection ports of any type are provided upon the generator. In this context no minimum hardware requirement exists, since the user has no ability to gain unauthorized access to the firmware.

Please read all Warning & Cautions contained in this document

The TORS System

Overview

TORS 1, Torsional Orthopedic, Revision System Series 1, is an ultrasonic PMMA cement removal device to provide state of the art performance and convenience in arthroplasty surgery, especially cemented joint revision. The system comprises a twin channel console that provides two Cement channels. These allow rapid probe interchange by the surgeon as well as 100% redundancy in case of damage/contamination. A large range of single use, sterile packed probes is available for the surgeon to choose from. All parts except the single use probes and the ergonomic, 360° finger-switch, plastic handpiece on the Cement Transducers, are washable, autoclavable and reusable.

Generator

Front Panel

The screen is highly visible, especially in a darkened operating theatre, indicates operating mode selected and gives concise instructions on action required in the event of disruption to normal operation.

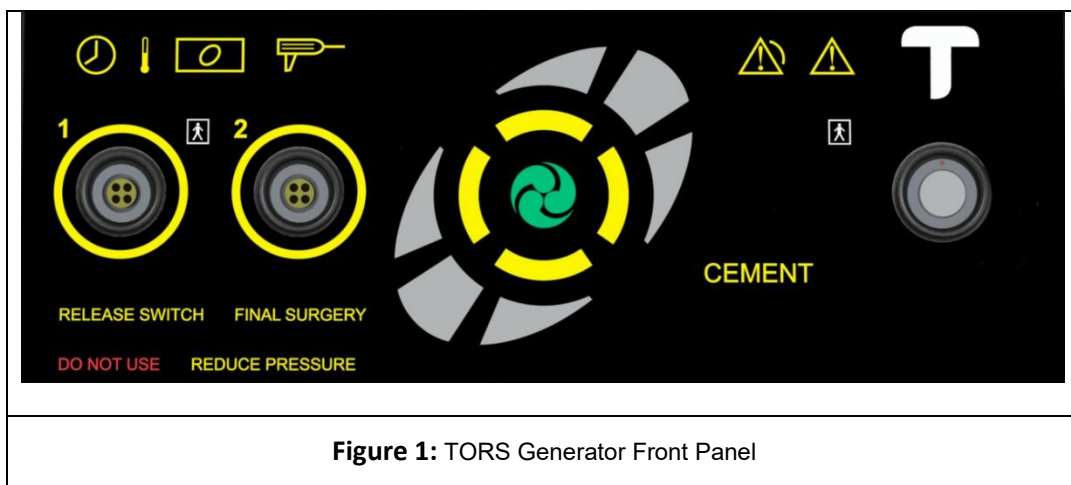

Figure 1: TORS Generator Front Panel

Rear Panel

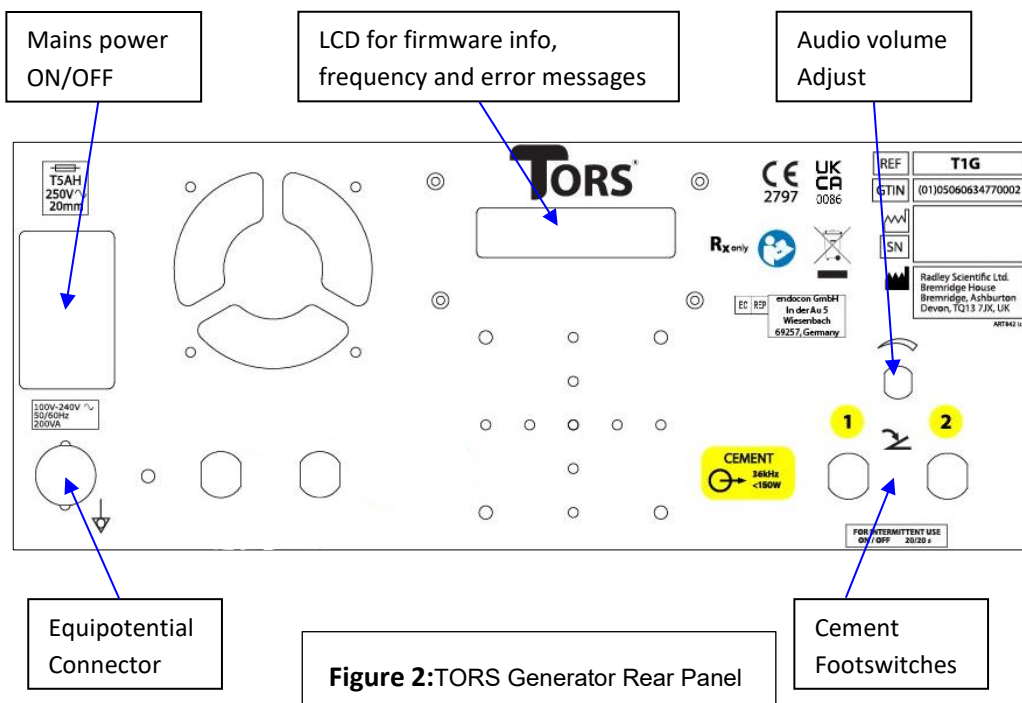

Figure 2: TORS Generator Rear Panel

There is only one user control on the Generator itself:

- Volume control (on the rear panel)

TORS Transducers & Cables

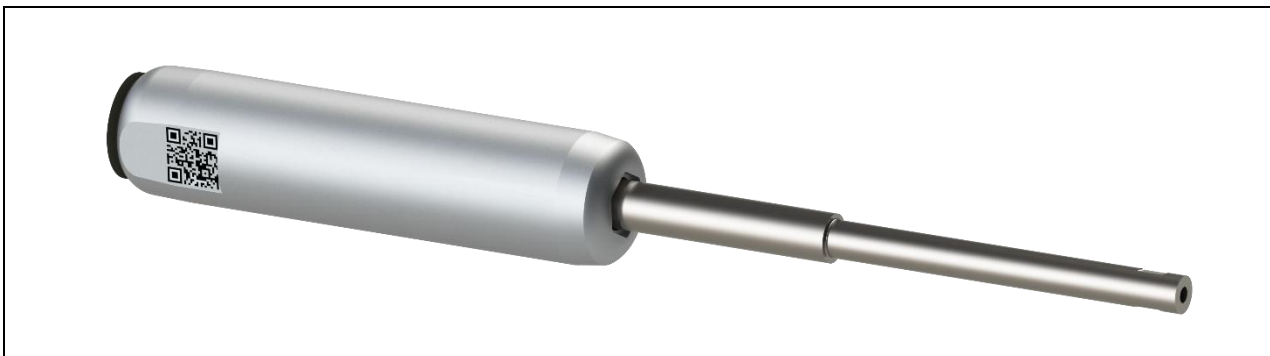

Figure 3: TORS Cement Transducer



Figure 4: Cement Cable

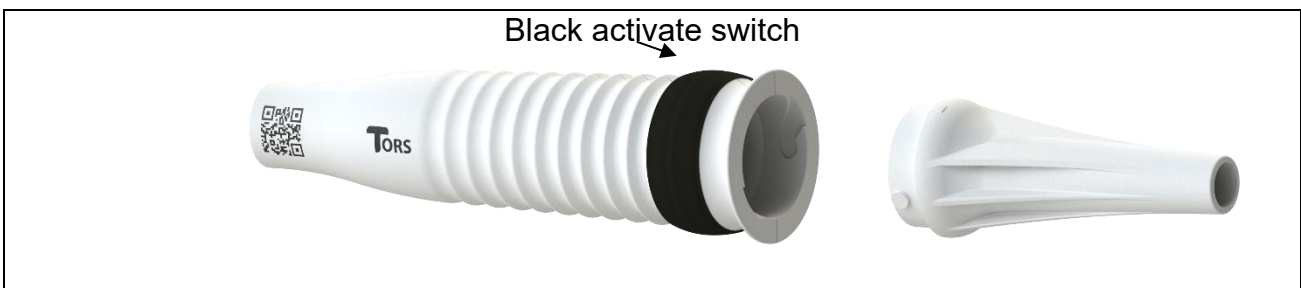

Figure 5: Axial Grip Handpiece



Figure 6: Axial Grip Handpiece with Cement Transducer, Probe, and Cement Cable fitted



Figure 7: Two single use sterile probe cartons

See Appendix 1 for the single use probe types and part numbers.

Safety

Warnings

- This device should only be used by surgeons who are (1) trained in the types of surgical procedures that are to be carried out and (2) trained in the specific use of ultrasonic surgical instruments.
- Do not operate TORS in a potentially explosive or flammable area, or in oxygen rich environments. Note that if the Probe touches anything metal while active, sparks may be produced.
- The use of TORS in cases where a patient or an operator of the unit has been fitted with a cardiac pacemaker is left to the discretion of the consultant in charge of the procedure. No electrical flow is made through or into the patient and many clinical papers on the use of ultrasound in the proximity of cardiac pacemakers have been published.
- Appropriate protective measures, including smoke evacuation, should be taken to protect users from any smoke, or other aerosols, produced by the use of surgical ultrasound.
- Use extreme caution when using in the vicinity of nerves.
- Handle reusable parts correctly in order to achieve full service-life.
- Do not attempt to modify the acoustics. No modification of this equipment is allowed.
- The use of transducers or handpieces not supplied as part of the TORS system may damage the Generator and create a safety hazard for the operator and patient.

- Avoid touching or holding the probe tip at the end of the active probe. Danger of burns!
- Other than the active tip, do not allow probe to be in contact with tissue.
- Irrigate the femoral canal after each activation.
- If the probe is deactivated inside heated PMMA it is possible the cooling cement will adhere very strongly to the probe, in which case it may become difficult to reactivate the probe in order to remove it from the cement.
- When guiding the TORS Cement Probe through PMMA, care must be taken not to exert excessive force in order to maintain control of the direction of travel of the probe.
- Use of excessive force in vicinity of thin bone may cause perforation.
- Avoid resting the hot probe tip on skin or other tissue for at least 60 s after cessation of energizing as it will have become hot while cutting. Ultrasonic systems dissipate heat quickly. (User may quench hot probe tip / blade in saline.)
- Care should be taken when in contact with tissue between activations, in case accidental activation should occur.
- If the probe comes into contact with bone, using recommended cooling strategies a bone temperature of up to 51°C may be seen.
- Allowing active tip to contact bone may cause damage to the bone.
- Wherever possible avoid contact between the side of active cement probe and patient tissue.
- Mains isolation is achieved by use of the double pole switch located on the rear panel. DO NOT position the equipment in such a way as to make access to this disconnection switch difficult.
- To avoid the risk of electric shock, this equipment must only be connected to a mains supply with protective earth.
- TORS is not MR safe or MR compatible.
- Do not re-sterilize or reuse any single use parts.
- Portable RF communications equipment (including peripherals such as antenna cables and external antennas) should be used no closer than 30 cm (12 inches) to any part of TORS, including cables specified by RSL. Otherwise, degradation of the performance of this equipment could result.
- TORS should not be used adjacent to or stacked with other equipment. If adjacent or stacked use is necessary, TORS should be observed to verify normal operation in the configuration in which it will be used.
- The use of accessories, transducers and cables other than those specified may result in increased emissions, decreased immunity or improper operation.
- There are no user serviceable parts.
- Do not combine multiple extension bars, only use one extension bar per cement probe and transducer.
- When attaching cement probes to the cement transducer, do not OVER-TIGHTEN the probe, a firm pressure applied with both spanners, is all that is required.

Cautions

- U.S. law restricts this device to sale by or on the order of a licensed physician.
- The nursing staff must be trained so that they are familiar with the equipment to be used.
- Before any sterile packed (single use) accessory for TORS is opened, it must be inspected for packaging integrity. The outer carton may be dented, crumpled or even punctured so long as the sealed pouch inside is not punctured. If a bend or wrinkle in the pouch makes puncture likely DO NOT OPEN/USE but return to manufacturer.
- Avoid allowing an active probe to come into contact with any metal surface. Any damage increases the risk of fatigue, which might result in tip detachment from the probe.
- Do not sterilize the TORS generator or footswitch.
- Do not allow the generator to enter the sterile field in theater.
- Do not block or otherwise restrict the vents on the rear and bottom panels.
- Never allow electrosurgical equipment to contact the probe.
- Do not spill any liquid upon the generator.
- Ensure that more than one single use axial-grip handpiece is available in case of accidental contamination.
- Always transport TORS using the supplied transport cases.
- The TORS generator has an Equipotential Terminal on the back panel. This is provided for compatibility with other medical systems requiring such connections. This conductor is not intended for protective earthing. Refer to EN 60601-1 for details of use with ME Systems.
- TORS:
 - i. should be used only for those procedures for which it is indicated.
 - ii. should be used with an appropriate power level commensurate with the required task.
 - iii. should be used with correct surgical technique.

If used correctly the TORS should remove PMMA cement to the satisfaction of the user.

The equipment should inform the user of its status either by audio or visual means, unless ultrasound output is not possible. However, if a fault with the audio or visual indicators occurs whilst a cut is in progress, it may allow that activation to be completed without indication.

Electromagnetic Interference

- This equipment is only suitable for use in hospital operating theatre / operating room.
- The performance of TORS may be degraded if it is subjected to electromagnetic disturbances e.g. an incorrect display that clears automatically once activate switch is pressed/depressed.
- Do not use TORS simultaneously with laser equipment or high frequency surgical equipment.
- This equipment has been tested and found to comply with the limits for a medical device.

However, should interference occur, the user can try the following measures: -

1. Turn equipment off and on to confirm the source of the interference.
 2. Increase separation between this equipment and other devices.
 3. Connect this equipment to a power socket different from that to which the other devices are connected.
 4. Consult medical physics department.
- The EMISSIONS characteristics of this equipment make it suitable for use in industrial areas and hospitals (CISPR 11 class A). If it is used in a residential environment (for which CISPR 11 class B is normally required) this equipment might not offer adequate protection to radio-frequency communication services. The user might need to take mitigation measures, such as relocating or re-orienting the equipment.
 - Where replacement transducers and cables are required, these must be manufactured by RSL (see Appendix 2 for full listing),
 - See also
 - Appendix 3: Electromagnetic Interference.

Complications and Potential Side-effects

General risks and complications of arthroplasty surgery

- Bone loss during prosthesis and/or cement removal
- Cortical perforation
- Fracture in the bone around the artificial joint
- Recovery time, pain and potential for arthritis associated with deliberate osteotomy
- Nerve/vascular lesions
- Rebleeding or hematoma / seroma
- Ligament, artery or nerve damage in the area around the knee joint
- Blood clots or deep vein thrombosis or pulmonary embolism
- Hemorrhage caused by tissue injury or ineffective hemostasis
- Bone/joint infection
- Late infection
- Infection of the wound and/or the tissue around the artificial joint
- Thromboembolism
- Implants or metal parts remaining in joint
- Fatigue fracture
- Excess bone forming around the artificial joint (knee) restricting movement
- Excess scar tissue forming and restricting movement
- Kneecap or hip dislocation
- Numbness in the vicinity of the wound scar
- Loosening of the artificial joint (normally after 10-15 years)
- Joint wear and tear
- Joint stiffening
- Bone cement implantation syndrome
- Hypoxia
- Hypotension
- Cardiac arrhythmias
- Cardiovascular collapse
- Thermal injury due to cement polymerization (setting) reaction
- Contact inhalational exposure to PMMA monomer leading to hypersensitivity
- Asthmatic reactions
- Neurological symptoms
- Localized irritation

- Personal risks from anesthetic or the surgery itself

Potential side-effects of ultrasonic arthroplasty surgery

- Necrosis and clinical dysfunction in femoral cortex and surrounding soft tissue due to heat transmission from ultrasonic probe/cement interface
- Intramedullary canal perforation
- Different tissues and bone cement will be heated to different degrees with the same ultrasound parameters
- Each cell type has a different susceptibility to thermal injury
- Pathologic humeral fracture
- Microscopic bone cracks
- Plume production (95% water, 5% cell debris)
- Radial nerve palsy
- Risk of cross-infection from re-sterilized reusable parts of the system
- Weakening of the remaining cortical bone
- Incomplete extraction of the cement
- Cement removal occurs more slowly than expected

MDR reportable event (or reportable event)

21 CFR 803.3(o) defines a MDR reportable event (or reportable event) as:

“(1) An event that user facilities become aware of that reasonably suggests that a device has or may have caused or contributed to a death or serious injury or

(2) An event that manufacturers or importers become aware of that reasonably suggests that one of their marketed devices:

(i) May have caused or contributed to a death or serious injury, or

(ii) Has malfunctioned and that the device or a similar device marketed by the manufacturer or importer would be likely to cause or contribute to a death or serious injury if the malfunction were to recur.”

In the event that a MDR reportable event (or reportable event) occurs in relation to the TORS device, the user facility should report it to the Manufacturer and to the FDA.

Instructions for Use

Note. Neither the generator nor any other component accessory of this device can be connected to an external network of any kind; no external connection ports of any type are provided upon the generator. In this context no minimum hardware requirement exists, since the user has no ability to gain unauthorized access to the firmware.

Setting Up the TORS System

Remove the protective film from the generator front panel, if it remains attached.

Power up the Generator

- Connect the mains lead to the rear panel of the Generator.
- Press the Mains rocker switch up, “I”, to switch on.
- The Generator will now power up with an audio indicator flourish of tones, conduct a brief full screen illumination test as shown in **Error! Reference source not found.**

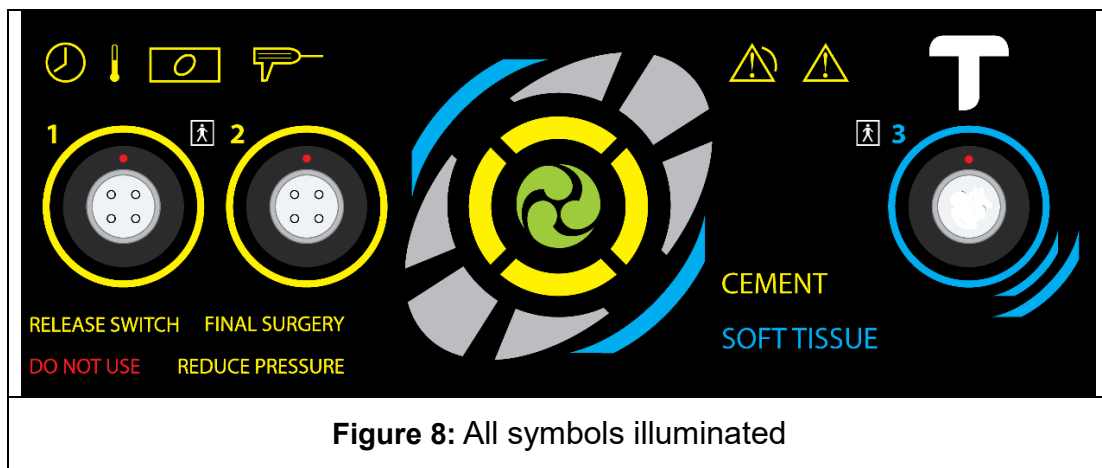

- After approximately one second the display will show:

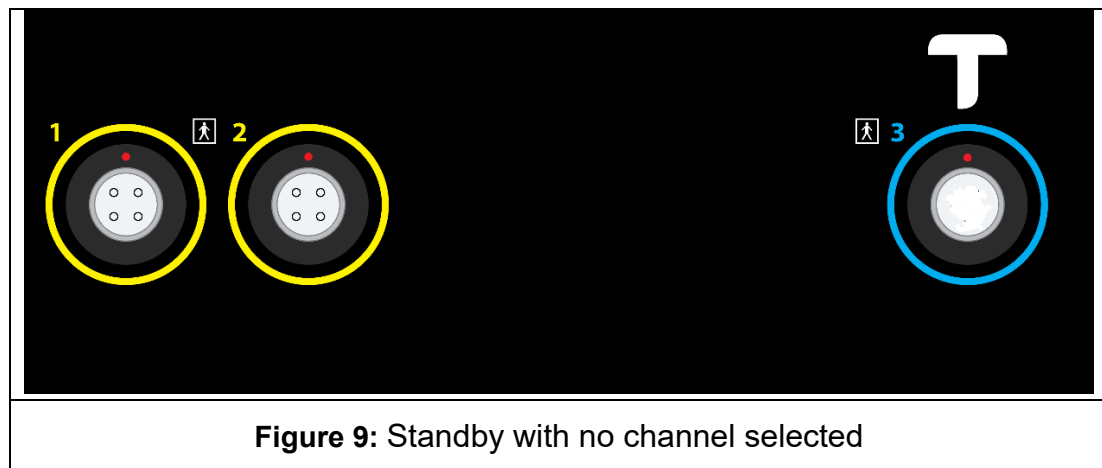

Note: The text and symbols in blue are not used during operation.

Optional - Attach the “Cement” footswitch to the Rear Panel

- The tube with the **Yellow** + “1” collar attaches to the similarly marked connection.
- The tube with the **Yellow** + “2” collar attaches to the similarly marked connection.

Assemble the Cement Transducer + Probe (Applied Part) in the sterile field.

- Select the pre-sterilized cement transducer.
- Outside the sterile field, open the carton of the required sterile probe (single use) and remove the double pouch. Open the outer pouch and offer the inner pouch into the sterile field. Inside the sterile field, open the inner pouch, remove the probe and remove its tip protector.
- Outside the sterile field, open the carton of the sterile axial-grip handpiece (single use) and remove pouch containing the tray+lid. Open the pouch and offer the tray+lid into the sterile field. Inside the sterile field, open the tray+lid and remove the handpiece grip and sleeve.
- Fit the transducer into the handpiece. Rotate the transducer and drop into place – ensure that it is securely connected. See (1) & (2) in Figure 10 below.
- Slide the handpiece sleeve over the Transducer horn. Locate the lugs at the base of the sleeve into the handpiece grip and twist / click into place. See (3) below.
- Using both supplied Wrenches, attach the probe to the transducer (4) & (5) below.
- **ALWAYS** use **BOTH** wrenches for tightening the probe to avoid damaging the cement transducer.

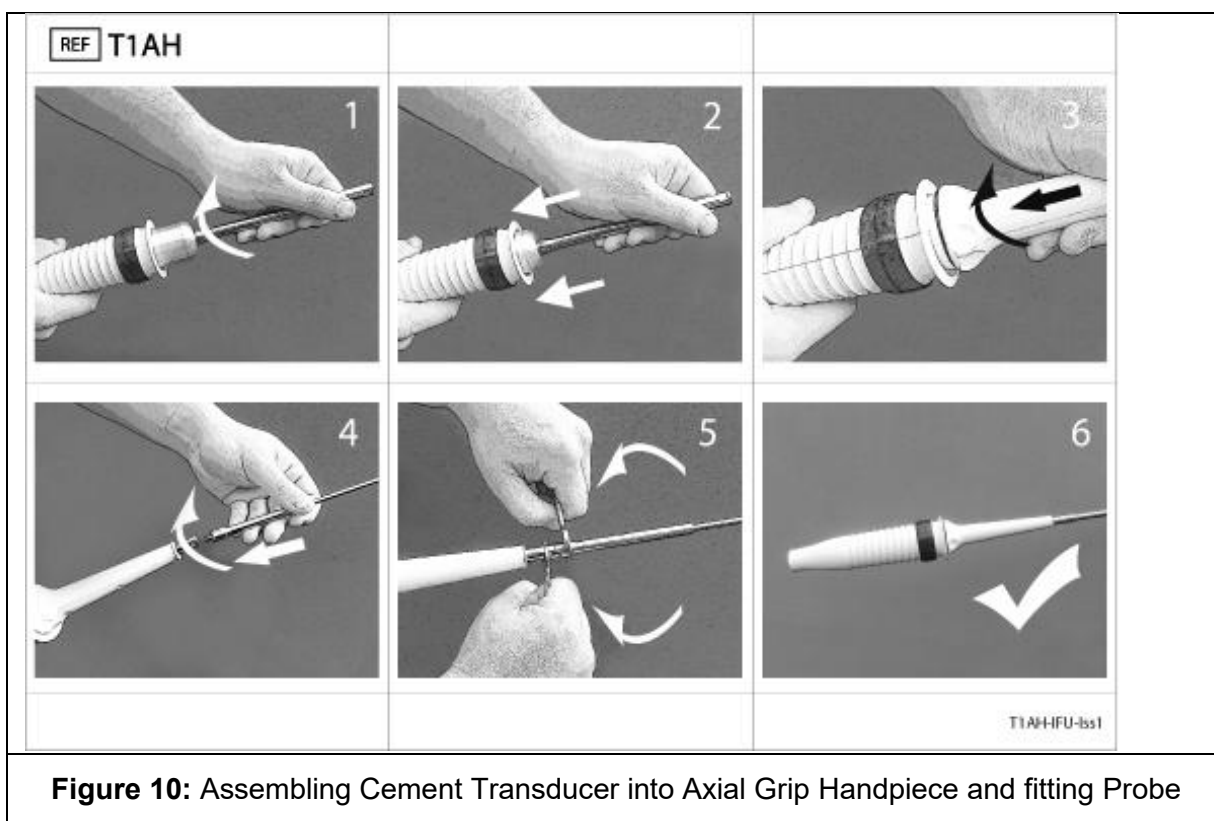

Cement Transducer - Connect

- Connect the Cement cable (Yellow coding to Generator Channel 1 or 2 (Yellow rings) by aligning the red dot on the metal plug with the red dot on the Generator socket. Push the plug into the socket until it clicks.

- Connect the other end of the Cement cable (Plastic connector) to the Cement handpiece. Align the arrow on the plastic connector with the spaces separating the two slots in the rear connector on the axial-grip handpiece. Click into place.
- To remove, pull back on the knurled part of the plug - **Do not** pull the cable.

Cement Transducer - Initialise

- When the surgeon is ready to use the transducer, they must initialize it to enable power. This is done simply by pressing the black activate button on the handpiece or the yellow footswitch (Ch1 or Ch2). The display shows:

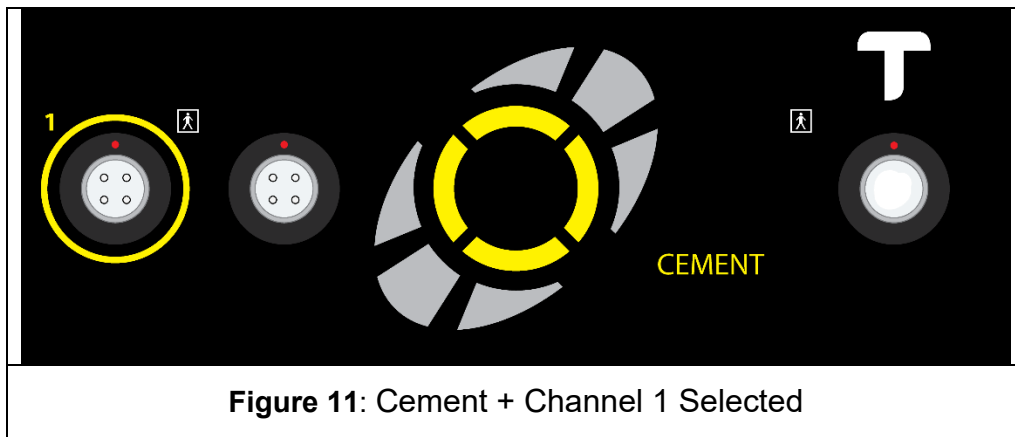

Cement Transducer - Activate

- Press the black activate button on the Handpiece or the yellow Footswitch. This will activate the Transducer and Probe for surgery. An audible indicator signifies power delivery with a continuous low-pitched tone.

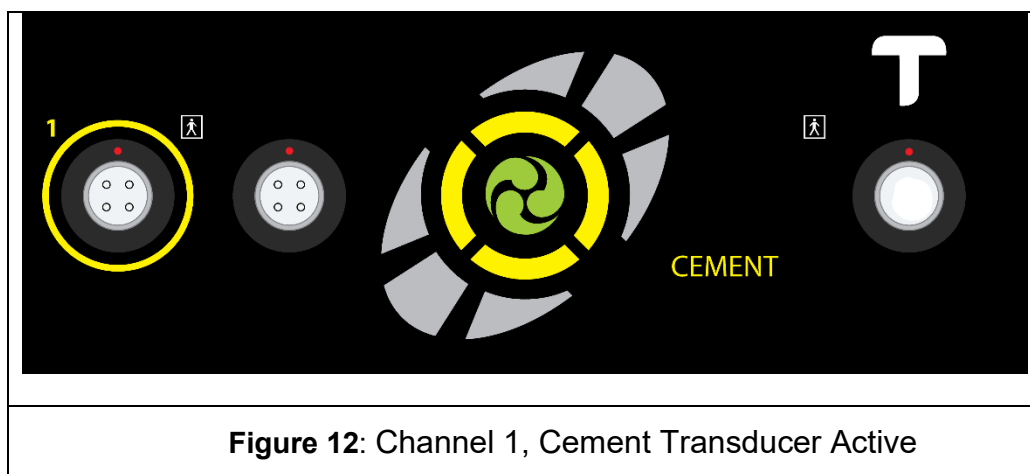

- To stop output, release the Footswitch or activate button.
- If the Footswitch or activate button is held down continuously for 20 seconds the audio indicator sound will change from continuous to pulsed.
- After a further 5 seconds the Generator will terminate power.
 - Output power is cut
 - Audible indicator stops
 - Displays Warning symbol + Transducer symbol + Clock symbol.
- These will remain illuminated as long as the Footswitch or activate button is pressed.
- When it is released, normal operation resumes

Cement Removal – Irrigation

It is important to irrigate the bone canal during the cement removal process for two reasons:
- It clears the canal of cement debris, including dust, and it also helps maintain safe operating temperatures within the canal. Such irrigation systems are standard provision in orthopaedic cases.

It is recommended that irrigation in the form of pulsed lavage or manual irrigation is used after each activation of any probe-type, piercer or scraper.

Do not irrigate *during* an activation as this may compromise the efficacy of the ultrasound transmission, translating to a slower cement removal process. The TORS probes are designed to produce rapid heating at the probe / PMMA interface, thus softening the cement. Any cooling during this process will impede the desired effect.

Any waste products should be disposed of as per normal hospital procedures.

Fume Extraction

It is recommended that a suitable extraction system is used to remove smoke, aerosols and any associated odors.

Any waste products should be disposed of as per normal hospital procedures.

Performance Characteristics

- **Cement Removal**

The different diameters of piercer probes will penetrate cement at different rates but the size range allows access into varying open cement canal diameters with consequent varying volumes of cement removed per “cut”.

Likewise, the different scraper probe sizes will remove varying volumes of material per “cut”.

The 4 mm piercer (P4S2) is intended specifically for penetrating hard, High-Density Polyethylene (HDPE), cement restrictors (distal plugs). It has no proximal cement trapping flange and will not remove material. Once an initial hole has been made larger piercers and scrapers can be used to erode and remove the plug. It is not recommended for use on the softer, PMMA, or gelatine, distal plugs.

The user should not apply excessive force, but instead, allow the ultrasound to advance the probe through the cement.

PMMA will not cause wear/damage to the probes. If there is evidence of wear/damage on a probe, then this is likely to be caused by the probe making contact with either the bone or a metal obstruction (stem, screw, nail *etc.*)









If the probe heads contact bone, then an audible squeal usually occurs and provides feedback to the user. The user should immediately redirect the probe head to avoid contact with bone. Sometimes the audible response may be damped out when the bone cavity is still densely packed with bone cement, or the user may not be able to hear the very high pitch of the audible feedback from the probe head on bone.

The squeal cannot be guaranteed as it is affected by the bone and cement properties as well as the probe angle, force and damping. If a TORS Piercer probe appears to be silent but NOT moving forward through material, or making smoke, then it may well be contacting bone. DO NOT CONTINUE TO PUSH without checking where the probe is. Real time X-ray is very effective at this point.

Turn Off TORS

- Press the black ON/OFF power switch at the rear of the unit. The screen will become entirely black.



Fault / Warning Indicators: (see also Appendix 4: Tones and Beeps)



 <p>The Illuminated yellow triangle indicates that a fault has occurred.</p>	It will always be accompanied by:	
	i. An illuminated symbol indicating the part of the equipment where the fault has occurred	
		
	ii. Illuminated text instructing the user e.g. Reduce Pressure	Or 
		Or 
Or 		
If warning relates to time, the clock symbol also illuminates		
If warning is temperature related the temp symbol also illuminates		

	<ul style="list-style-type: none"> • Too much force is being applied to the TDCR during activation. Reduce applied force to improve performance. Excessive force applied during activation can impede cutting performance. • No transducer connection. • Probe tip is too hot. Allow probe tip to cool.
---	--

	<p>Handpiece button or footswitch held in. A high-low tone will sound.</p>
---	--

	<p>Generator has over-heated. Check air vent below generator is un-impeded. A high-low tone will sound. Try again after 5- 10s.</p>
---	---



 <p>+</p>  <p>+</p> 	<p>The generator has detected a problem with the connections to the transducer. The warning triangle will illuminate and a triple high-high-high tone will sound and repeat. Switch OFF then ON to clear fault. Re-activate the transducer away from the patient – if fault recurs then change the transducer and return for service.</p>
---	---



 <p>+</p> 	<p>The Generator has detected a problem. The warning triangle will illuminate and a triple high-high-high tone will sound and repeat. Switch OFF then ON to clear fault. Switch generator back on – if fault recurs then return the system for service.</p>
--	---

DECONTAMINATION

In order to replicate the validated decontamination and sterilization processes for the TORS device, Sterilization and Decontamination Units must operate procedures and equipment that conform to ISO 17665-1. Validation of the sterilization process has been completed for steam autoclave cycles with an active phase of 3 minutes at 134°C.

TORS Accessories Requiring Sterilization Before Use

 <p>These accessories are all supplied in a non-sterile condition and are reusable. The end user must complete decontamination and sterilization processes before use/re-use.</p>	
Cement Transducer (Applied Part)	SKU
	T1CT
Cement cable	SKU
	T1CC

<p align="center">Short and Long Extension Bars Short – straight and curved – 70 mm Length Long - straight – 140mm</p>	<p align="center">SKU</p>
	<p align="center">ECR1 ESR1 ESR2</p>
<p align="center">Wrench x2</p>	<p align="center">SKU</p>
	<p align="center">T1S</p>
<div align="center">  <p>NON STERILE</p> </div> <p>These accessories are all supplied in a non-sterile condition and are reusable. The end user must complete decontamination and sterilization processes before use/re-use.</p>	
<p align="center">Figure 13: Patient contacting parts that must be sterilized before use</p>	

Please refer to the separate Decontamination Certificate and Instruction (WIG0006 App1) provided with the Instrument Kit; this document provides all of the details for each of the following subjects:

- **After Use Re-Processing**

Immediately after use wipe down all components and remove any surplus body fluids and debris.

Detach the Cement Cable(s) from the Cement Transducer(s) by disconnecting from the handpiece.

Remove the Sleeve from the Grip on the Cement Handpiece. Detach the Handpiece from the Cement Transducer by pulling the Transducer and the Handpiece apart.

Detach the Cement probe from the Cement Transducer using BOTH supplied wrenches.

Replace the Transducers, Cables and wrenches back into the autoclave tray, preferably within its original wrap to reduce drying of soil while it is returned to the cleaning facility.

- **Single Use Items**

Dispose of the Cement Handpiece Grip and Sleeve and the opened/used probes as per hospital protocols.

- **Reusable Items**

- **Manual Cleaning**

Prepare enzymatic cleaning solution (e.g. Gigazyme Plus) to manufacturer's instructions.

Soak soiled instruments in enzymatic solution for 5 minutes.

When cleaning, fully submerge the instruments in the cleaning solution. Brush with soft non-metallic bristle brush or cloth to remove all traces of blood and debris, concentrating on any crevices, seams, or other surface discontinuities. Clean holes and recesses using an appropriate brush ensuring that the full depth of the feature is reached. Ensure instruments are visibly clean before progressing to the next step.

Rinse instruments thoroughly with clean running water for 2 minutes. Ensure that blind holes and recesses are repeatedly filled and emptied with running water.

Dry instruments immediately after final rinse. Do not exceed 140°C (285°F)

- **Automated Cleaning**

Instruments may require manual cleaning prior to automated cleaning to improve the removal of adherent soil. Brush with a non-metallic bristle brush in enzymatic cleaning solution.

Load instruments such that crevices, seams, surface discontinuities, holes and recesses can drain.

Clean using the "Instruments" cycle in a validated washer disinfectant and a pH neutral cleaning agent intended for use in automatic cleaning (e.g. Getinge Enzymatic Detergent). The cleaning cycle should incorporate pre-rinse, wash, rinse, thermal rinse and drying steps. The duration and temperature of the steps may vary between different washing systems/devices but any washer/disinfectant cycle which is validated to ISO 15583-1, ISO 15883-2 & HTM 01-01 part D is suitable for processing the TORS device(s). Do not exceed 140°C (285°F).

An alkaline cleaning solution such as, for example, Serchem pH Plus Detergent, with a pH up to 13.2 may be used instead of, or in addition to, an enzymatic solution.

- **Cleaning Inspection**

Inspect all instruments prior to sterilization or storage to ensure the complete removal of soiled surfaces.

Visually inspect instruments, if soil is still present clean instruments again.

Inspect cables for wear and damage, ensuring that no cracks, tears, or other damage is found.

Report any damage found to your supplier/distributor representative.

- **Wrapping**

Double wrap in accordance with local procedures, using standard procedures wrapping techniques such as those described in HTM 01-01 or ANSI/AAMI ST46-1993.

Label contents of wrapped tray using indelible marker or other sterilization compatible label system.

- **Sterilization**

Sterilization is best achieved on the day preceding the surgery, but must be at least one hour prior to use to allow the equipment to cool and stabilize.

⚠ Transducers are NOT to be submerged in water to expedite cooling.

⚠ Do NOT sterilize the Generator or Footswitches

These components have been validated for sterilization by the following method in a vacuum autoclave. The parameters for this being 270°- 277°F for a minimum of 3 and a maximum of 4 minutes.

Next Use - After decontamination, the Transducers, Cement cables and wrenches can be re-sterilized as above.

- **Drying Time**

After sterilization at 270°F the validated drying time is 30 minutes.

- **End of Life Management**

TORS generator and all reusable accessories (including Transducers) should be recycled. Contact RSL for return instructions - see end page of this IFU.

A valid decontamination certificate MUST accompany any returned reusable accessories.

- **Opened in Error**

In the event of a Single Use Handpiece or probe being unwrapped in error, it may not be re-sterilized.

Care should be taken to ensure that the cables are not kinked during sterilization as this can produce cracks in the cable and reduce cable life.

- **Cleaning the Generator**

The TORS Generator may be cleaned as follows:

- i. Dilute a neutral pH detergent according to the manufacturer's directions.
- ii. Using above solution, lightly moisten a soft, clean cloth. Wipe surfaces of the Generator.
- iii. Using tap water, lightly moisten a soft, clean cloth. Wipe surfaces of the Generator.
- iv. Dry Generator surfaces with a soft clean cloth.

- **Cleaning the Footswitch**

The TORS Footswitches may be cleaned as follows:

- i. Dilute a neutral pH detergent according to the manufacturer's directions.
- ii. Using above solution, lightly moisten a soft, clean cloth. Wipe surfaces of the Footswitch.
- iii. Using tap water, lightly moisten a soft, clean cloth. Wipe surfaces of the Footswitch.
- iv. Dry Footswitch surfaces with a soft clean cloth.
- v. Do not allow any water to enter into the air-hoses.
- vi. Do not detach the air hoses from the Footswitch.

Equipment Care

Transducer / Probe Usage

The cement transducers of TORS can be decontaminated and reused. However, they cannot be reused indefinitely as the piezo crystals inside will depolarize over time and so service lifetimes are defined within which optimum performance can be expected. Therefore, transducers must be replaced when necessary.

The cement transducer lifetime is not limited by the system as its usage time is not monitored by the generator. It should be changed if cutting performance deteriorates. As a guide it may be changed after an average service life of 10 minutes ON-time per case, over 25 cases = 250 minutes ON-time.

Cement Probes are supplied sterile and for single patient use. They should be changed if contact with non-PMMA materials such as metal causes deformation and cutting performance deteriorates.

TORS probes are susceptible to damage if forced into contact with metal (e.g. hand instruments and clamps) when active. The consequence of deformation or scratching a probe is to raise the mechanical stress in the region of the scratch (creating a "stress raiser") when the probe is vibrating. If the stress is raised sufficiently there is a risk of the probe suffering metal fatigue and cracking. Fatigue failure is more likely if the stress raiser is close to one of the fixed points of maximum mechanical stress in the vibrating probe. If a probe does suffer

metal fatigue as a result of a stress raiser causing a crack, the probe will no longer possess a resonant frequency “recognizable” by the generator and cannot be activated by the generator.

Storage of Equipment between Cases

It is recommended that the transducers (with associated cables) are stored, between cases, in the large autoclave tray provided and again, care should be taken to ensure that the cables are not kinked close to the connector.

Maintenance

The hospital is responsible for ensuring that the unit has an electrical safety check performed by qualified service personnel at least once a year.

Do not remove the covers from TORS.

TORS generator does not require periodic calibration. If the generator detects an internal problem, it will display a “Service Due” on the rear LCD. If this is seen, contact RSL to arrange repair.

There are no user-serviceable parts in TORS.

Any damage to the transducers or cables should be reported and the components returned to the supplier at the earliest opportunity.

Technical Support

In line with the company's policy of quality assurance and customer care, RSL offers a telephone helpline service for users of TORS. This is provided by the TORS manufacturer, RSL at its facility in Devon, England.

United Kingdom HELPLINE Telephone No. as displayed on the unit is:

+44 (0)7966 911670

US Agent and Importer:

DAWA MEDICAL LLC
7320 NW 12th Street,
Suite 103,
Miami,
Florida,
33126 USA

Email : customerservices@dawamedical.com

Phone: (305) 599-9373

Website: dawamedical.com/

APPENDICES















Appendix 1:











a. TORS Non-sterile System and Accessory Part Numbers

ITEM	Product Code	GTIN
Probe Extension Bar - Straight (Reusable)	ESR1	05060634770989
Probe Extension Bar - Curved (Reusable)	ECR1	05060634770996
Probe Extension Bar - Long - Straight (Reusable)	ESR2	05060634770972
Cement Transducer (Reusable)	T1CT	05060634770064
Cement Cable (Reusable)	T1CC	05060634770071
Generator	T1G	05060634770002
Mains Power Cordset US	MPC-US	05060634770958
Generator Carry Case	T1GC	05060634770040
Cement Footswitch	T1FC	05060634770019
Autoclave Tray	T1AT	05060634770095
Autoclave Tray Mat	T1SM	05060634770101
Instrument Carry Case	T1IC	05060634770118
Wrench	T1S	05060634770354

b. TORS Sterile Consumable Part Numbers















<p>Supplied sterile (ethylene oxide) DO NOT USE IF PACKAGING HAS BEEN DAMAGED!</p>  <p>STERILE EO</p>	
Single-Use Cement Axial Grip Handpiece	SKU
	T1AH
Single-Use Cement Piercer Probes – 200 mm Length	SKU
	P4S2





	P6S2
	P8S2
	P10S2
	P12S2
	P14S2
Single-Use Cement Scraper Probes – 200 mm Length	SKU
	S6S2
	S8S2
	S10S2
	S12S2
	S14S2
Single-Use Cement Piercer Probes – 100 mm Length	SKU
	P6S1
	P8S1
	P10S1
	P12S1

	P14S1
Single-Use Cement Scraper Probes – 100 mm Length	SKU
	S6S1
	S8S1
	S10S1
	S12S1
	S14S1
Single-Use Cement Slap Hammer Probe – 200 mm Length	SKU
	H10S2
Single-Use Cement Chisel Probe – 100 mm Length	SKU
	C6S1
<p>Supplied sterile (ethylene oxide) DO NOT USE IF PACKAGING HAS BEEN DAMAGED!</p>  	
Figure 14: Patient contacting parts that are supplied sterile	

ITEM	Product Code	GTIN
Box of 10 Single Use Axial-Grip Handpieces (Sterile)	T1AHx10	05060634770316
Cement 100mm Ø6mm Piercer Probe (Sterile)	P6S1	05060634771146
Cement 100mm Ø8mm Piercer Probe (Sterile)	P8S1	05060634771153
Cement 100mm Ø8mm Piercer Probe (Sterile)	P10S1	05060634771290
Cement 100mm Ø12mm Piercer Probe (Sterile)	P12S1	05060634771306
Cement 100mm Ø14mm Piercer Probe (Sterile)	P14S1	05060634771313
Cement 200mm Ø4mm Piercer Probe (Sterile)	P4S2	05060634771115
Cement 200mm Ø6mm Piercer Probe (Sterile)	P6S2	05060634770576
Cement 200mm Ø8mm Piercer Probe (Sterile)	P8S2	05060634770590
Cement 200mm Ø10mm Piercer Probe (Sterile)	P10S2	05060634771092
Cement 200mm Ø12mm Piercer Probe (Sterile)	P12S2	05060634771276
Cement 200mm Ø14mm Piercer Probe (Sterile)	P14S2	05060634771283
Cement 100 Ø6 Scraper Probe (Sterile)	S6S1	05060634771160
Cement 100 Ø8 Scraper Probe (Sterile)	S8S1	05060634771177
Cement 100 Ø10 Scraper Probe (Sterile)	S10S1	05060634771344
Cement 100 Ø12 Scraper Probe (Sterile)	S12S1	05060634771351
Cement 100 Ø14 Scraper Probe (Sterile)	S14S1	05060634771368
Cement 200mm Ø6mm Scraper Probe (Sterile)	S6S2	05060634771122
Cement 200mm Ø8mm Scraper Probe (Sterile)	S8S2	05060634770552
Cement 200mm Ø10mm Scraper Probe (Sterile)	S10S2	05060634771139
Cement 200mm Ø12mm Scraper Probe (Sterile)	S12S2	05060634771320
Cement 200mm Ø14mm Scraper Probe (Sterile)	S14S2	05060634771337
Cement 100mm 6mm Chisel Probe (Sterile)	C6S1	05060634771375
Cement 200mm 10mm Slap Hammer Probe (Sterile)	H10S2	05060634771382

Appendix 2: Markings on the TORS front and back panels

	Cement transducer selected
	Cement transducer output - Channel 1
	Cement transducer output – Channel 2
	Transducer active
	Model number
	Serial number
	Manufacturer
	Date of manufacture
	FUSE rating – Time delay, 5A, High breaking capacity, 250 Volts AC, size 20mm
100-240V	Mains AC voltage range
	Alternating current
50/60Hz	Mains AC frequency
200VA	Input power
	Warning sign
	Type BF equipment
36kHz	Cement frequency of output
<150W	Cement output power
For Intermittent Use ON/OFF 20/20s	Cement duty cycle
	Volume
	Footswitch connection

	Equipotential connection
	Output channel
	Follow instructions for use
	Electrical and Electronic equipment. Return waste to a collection system or treatment and recycling facilities. Follow decontamination instructions before returning waste.
	General caution sign

Appendix 3: Electromagnetic Interference

Table 1

Guidance and manufacturer's declaration – electromagnetic emissions		
TORS T1G is intended for use in the electromagnetic environment specified below. The customer or the user of TORS should assure that it is used in such an environment.		
Emissions Test	Compliance	Electromagnetic environment - guidance
RF emissions CISPR 11	Group 1	TORS uses RF energy only for its internal function. Therefore, its RF emissions are very low and are not likely to cause any interference in nearby electronic equipment. TORS is suitable for use in all establishments other than domestic and those directly connected to the public low-voltage power supply network that supplies buildings used for domestic purposes.
RF emissions CISPR 11	Class A	
Harmonic emissions IEC 61000-3-2	No testing – not connected to public mains network	
Voltage fluctuations /flicker emissions IEC 61000-3-3	No testing – not connected to public mains network	

Table 2

Guidance and manufacturer's declaration – electromagnetic immunity			
TORS is intended for use in the electromagnetic environment specified below. The customer or the user of TORS should assure that it is used in such an environment.			
IMMUNITY test	IEC 60601 test level	Compliance level	Electromagnetic environment - guidance
Electrostatic discharge (ESD) IEC 61000-4-2	±8 kV contact ±15 kV air	±6 kV contact ±8 kV air (1)	Floors should be conductive. No synthetic material should be used in the environment. The relative humidity should be in the range 40% to 60%.
Electrical fast transient/burst IEC61000-4-4	±2 kV for power supply lines	±2 kV for power supply lines	Mains power quality should be that of a typical commercial or hospital environment.
Surge IEC 61000-4-5	±1 kV differential mode ± 2 kV common mode	±1 kV differential mode ± 2 kV common mode	Mains power quality should be that of a typical commercial or hospital environment.
Voltage dips, short interruptions and voltage variations on power supply input lines IEC 61000-4-11	0 % U_T ⁽²⁾ (100 % dip in U_T) for 0.5 cycle at: 0°, 45°, 90°, 135°, 180°, 225°, 270°, 315° 0 % U_T (100 % dip in U_T) for 1 cycles 70 % U_T (30 % dip in U_T) For 25/30 cycles 0 % U_T (100 % interrupt in U_T) for 250/300 cycles	0 % U_T (100 % dip in U_T) for 0.5 cycle at: 0°, 45°, 90°, 135°, 180°, 225°, 270°, 315° 0 % U_T (100 % dip in U_T) for 1 cycles 70 % U_T (30 % dip in U_T) For 25/30 cycles 0 % U_T (100 % interrupt in U_T) for 250/300 cycles	Mains power quality should be that of a typical commercial or hospital environment. If the user of TORS requires continued operation during power mains interruptions, it is recommended that TORS be powered from an uninterruptible power supply.
Power frequency (50/60 Hz) magnetic field IEC61000-4-8	3 A/m	No testing	No magnetically sensitive components.
<p>NOTES:</p> <p>Mitigation applied because of environment.</p> <p>U_T is the a.c. mains voltage prior to application of the test level.</p>			

Table 3

Guidance and manufacturer's declaration – electromagnetic immunity			
TORS is intended for use in the electromagnetic environment specified below. The customer or the user of TORS should assure that it is used in such an environment.			
IMMUNITY test	IEC 60601 test level	Compliance level	Electromagnetic environment - guidance
Conducted RF IEC 61000-4-6	3V rms	3V rms	Portable and mobile RF communications equipment should be used no closer to any part of TORS, including cables, than the recommended separation distance calculated from the equation applicable to the frequency of the transmitter. Recommended separation distance $d = 1.2\sqrt{P}$, 150 kHz to 80 MHz $d = 1.2\sqrt{P}$, 80MHz to 800MHz $d = 2.3\sqrt{P}$, 800MHz to 2.3GHz where P is the maximum power output rating of the transmitter in watts (W) according to the transmitter manufacturer and d is the recommended separation distance in metres (m).
	150kHz to 80 MHz Outside ISM bands		
Radiated RF IEC 61000-4-3 Immunity to proximity fields from RF wireless communications equipment	6V rms In ISM bands 0.15MHz to 80MHz 80% AM at 1kHz	6V rms	Field strengths from fixed RF transmitters, as determined by an electromagnetic site survey, ^a should be less than the compliance level in each frequency range. ^b Interference may occur in the vicinity of equipment marked with the following symbol. 
	3 V/m 80MHz to 2.5GHz	3 V/m	
	9 V/m 710MHz, 745MHz, 780MHz, 5240MHz, 5500MHz, 5785MHz	9V/m	
	27 V/m 385MHz	27V/m	
	28 V/m 450MHz, 810MHz, 870MHz, 930MHz, 1720MHz, 1845MHz, 1970MHz, 2450MHz	28V/m	
NOTE 1 At 80 MHz and 800 MHz, the higher frequency range applies NOTE 2 These guidelines may not apply in all situations. Electromagnetic propagation is affected by absorption and reflection from structures, objects and people.			
<i>a Field strength from fixed transmitters, such as base stations for radio (cellular/cordless) telephones and land mobile radios, amateur radio, AM and FM radio broadcast and TV broadcast cannot be predicted theoretically with accuracy. To assess the electromagnetic environment due to fixed RF transmitters, an electromagnetic site survey should be considered. If the measured field strength in the in the location in which TORS is used exceed the applicable RF compliance level above, TORS should be observed to verify normal operation. If abnormal performance is observed, additional measures may be necessary, such as re-orienting or relocating TORS.</i>			
<i>b Over the frequency range 150 kHz to 80 MHz, field strengths should be less than 3 V/m</i>			

Table 4

Recommended separation distances between portable and mobile RF communications equipment and TORS			
TORS is intended for use in an electromagnetic environment in which radiated RF disturbances are controlled. The customer or the user of TORS can help prevent electromagnetic interference by maintaining a minimum distance between portable and mobile RF communications equipment and TORS as recommended below, according to the maximum output power of the communications equipment.			
Rated maximum output power of transmitter	Separation distance according to frequency of transmitter		
	m		
	150 kHz to 80 MHz $d = 1.2\sqrt{P}$	80 MHz to 800 MHz $d = 1.2\sqrt{P}$	800MHz to 2.5 GHz $d = 2.3\sqrt{P}$
0.01	0.12	0.12	0.23
0.1	0.38	0.38	0.73
1	1.2	1.2	2.3
10	3.8	3.8	7.3
100	12	12	23

For transmitters rated at a maximum output power not listed above, the recommended separation distance d in metres (m) can be estimated using the equation applicable to the frequency of the transmitter, where P is the maximum output power rating of the transmitter in watts (W) according to the transmitter manufacturer.

NOTE 1 At 80 MHz and 800 MHz, the higher frequency range applies

NOTE 2 These guidelines may not apply in all situations. Electromagnetic propagation is affected by absorption and reflection from structures, objects and people.

Appendix 4: Tones and Beeps

Rising flourish	TORS is booting to standby mode
No Tone	TORS is in standby mode
Triple tone – low-medium-low pitch	Handpiece activate button has been pressed to initialize handpiece (cement)
Continuous low pitched tone	Acoustic output for the cement transducer
Double beep –high>low pitch	The Generator has reset itself after a minor problem such as time-out or over-temperature but the most common event is frequency mis-tuning due to probe over-damping. So, generally this tone means: “Over-loaded probe, reduce pressure and try again”
Triple beep – high>high>high pitch	A more serious problem has been detected.

Appendix 5: Rear Panel Messages

The LCD on the rear panel will display messages that indicate the status of the equipment. The following table shows the possible displays:

Message	Status	Action required
Radley Scientific Ltd TORS Issue x	Startup message. Shows the Issue number of the software "X"	Now awaiting transducer to be plugged in
Cement Ready	The toggle switch has been operated and the relevant transducer is ready to be activated.	Now awaiting use
36000Hz Cement Active	While transducer is active the top line will show the frequency. After releasing the switch, it will display the final running frequency.	No action required
Active Too long Release Switches	The active button has been held on for too long. No output.	Release activate button on handpiece or on footswitch
Release Switches	Either activate or toggle button (or Footswitches) has been pressed at switch on.	Release Activate or Toggle button when switching on generator
Check Transducer Ease Grip and Retry	Transducer has been loaded too heavily	Release switch, then reactivate using less pressure on the jaw
	Transducer is too hot.	Allow transducer to cool.
Change Transducer Restart	Transducer frequency too low and feedback signal is low.	Switch supply off & on. Replace transducer if seen 3 times.
Transducer Leakage Change Tdcr	Generator has detected voltage on the transducer.	
Frequency Error Service due	The generator has detected a serious internal problem.	Switch supply off & on. If message seen again generator requires service.

Appendix 6: Technical Specification

Dimensions: Generator:	340 mm (width) x 95 mm (height) x 375 mm (depth) 13.4" (width) x 3.7" (height) x 14.8" (depth)
Weight: Generator:	7.6 kg
Transport case:	13.8 kg (loaded with generator)
Transducer:	0.37 kg
Fuse Type:	T5A, 250 V, 20 mm (2 off)
Cordset	Contact RSL for recommended type
Power supply input	100V – 240 V, 50/60 Hz
Power consumption	200 VA
Cement Output - Frequency of operation	36k Hz
Cement Output – Power	<150 W
Cement Mode of Operation	Intermittent ON/OFF, 20/20 s
Cement Transducer Classification:	Type BF
Insulation Classification	Generator: Class 1
Transducer	Titanium, stainless steel, and plastic. Autoclavable maximum 25 cycles for the Cement Transducer.
Environment for Transportation & Storage: (Except T1AH – Sterile Handpiece)	Temperature: -10°C to +50°C Relative humidity: 10% to 90% Atmospheric pressure: 50 kPa to 106 kPa
Environment for Storage of: T1AH Sterile Handpiece	Temperature: +10°C to +35°C Relative humidity: 30% to 50% Atmospheric pressure: 50 kPa to 106 kPa
Environment for Use:	Temperature: +10°C to +30°C Relative humidity: 30% to 75% Atmospheric pressure: 81 kPa to 106 kPa

TORS has been designed and built-in accordance with ISO 13485: 2016 Quality Assurance standard for medical devices.

CE conformance has been certified and the equipment complies with:

IEC 60601-1:2005 + CORR. 1:2006 +
CORR.2:2007 + A1:2012
EN 60601-1:2006 + A11:2011 + A1:2013
ANSI/AAMI ES60601-1:2005/ (R) 2012

Appendix 7: Warranty Statement

Subject to the terms and conditions listed in the warranty document (available on request), Radley Scientific Ltd. guarantees to replace or repair free of charge any defective parts of TORS notified within the warranty period. This applies to the hardware associated with TORS for the purposes of warranty claims made by any party supplied directly by the Company or its authorized representative.



Bremridge House,
Bremridge,
Ashburton
S. Devon
TQ13 7JX
UK

Tel: +44 (0)7966 911670 – Helpline

www.tors.co.uk

US AGENT and IMPORTER:
DAWA MEDICAL LLC
7320 NW 12th Street,
Suite 103,
Miami,
Florida,
33126 USA

DISTRIBUTOR:
SUMMIT MEDICAL
Bourton Industrial Park,
Bourton-on-the-Water,
Gloucestershire,
GL54 2HQ,
United Kingdom